

PLAN COFRAJ FORMWORK PLAN Sc 1:50

VEDERE A-A
A-A VIEW

VEDERE B-B
B-B VIEW

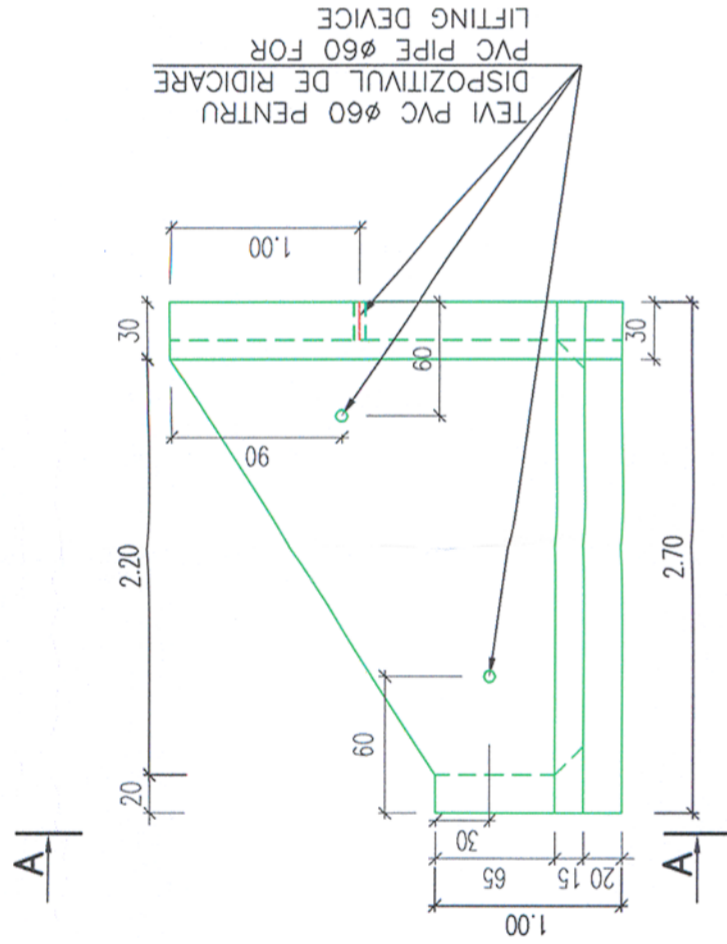
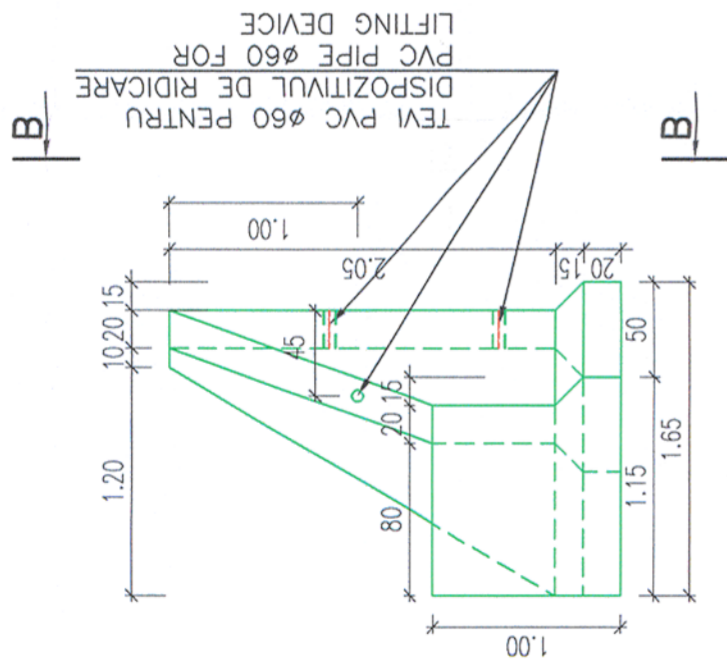

PLAN ARIPIA A1 STANGA
LEFT WING A1 PLAN

PLAN ARIPIA A1 DREAPTA
RIGHT WING A1 PLAN

TEVI PVC Ø60 PENTRU DISPOZITIVUL DE RIDICARE PVC PIPE Ø60 FOR LIFTING DEVICE

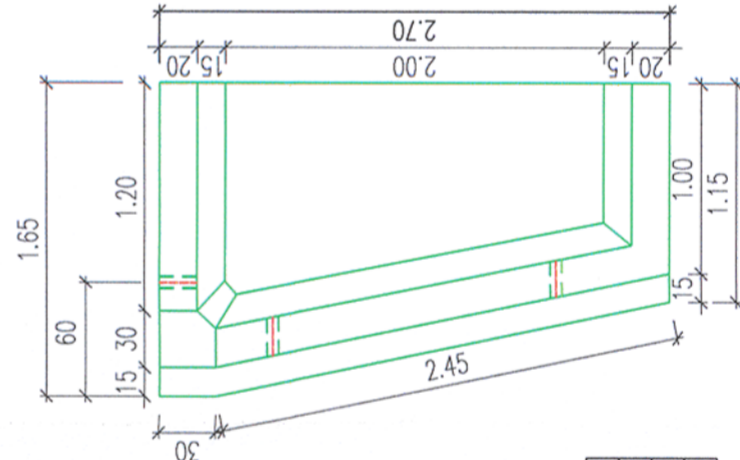
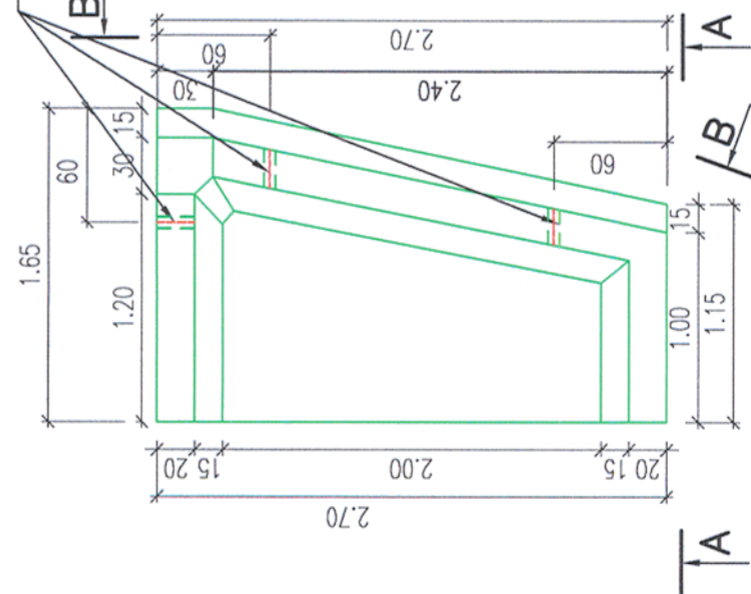

CARACTERISTICILE UNEI ARIPI ONE WING CHARACTERISTICS

1	Volumul de beton / V concrete	2.65mc
2	Otel PC 60 / Steel PC60	218.00kg
3	Cofraje / Formwork	20.35mp
4	Greutate / Weight	16.60t

FIGURA 1
FIGURE 1

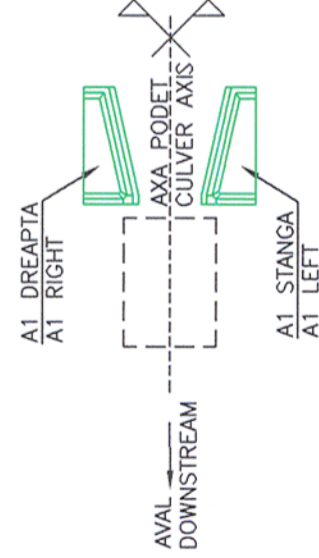

CARACTERISTICILE BETONULUI

C 35/45, expunere XC4+XF3+XA1 (R0), Cl 0.2, agregate D_{max} 22, densitate D 2.5, consistenta S3
C 35/45, expunere XC4+XF3+XA1 (R0), Cl 0.2, agregate D_{max} 22, densitate D 2.5, consistenta S3

BETON C35/45 OTEL PC60 ACOPERIRE 4cm
CONCRETE C35/45 PC60 STEEL COVERING 4cm

NOTA / NOTE

Acest plan este valabil pentru zone seismice cu acceleratie orizontala de varf $a_{g0} \leq 0.12g$.
This plan applies to seismic zones with top horizontal acceleration $a_{g0} \leq 0.12g$.

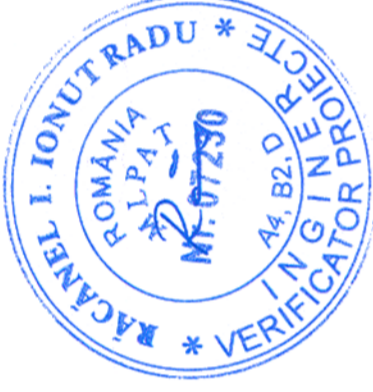

Prezentul plan anuleaza si inlocuieste versiunea anterioara
This plan cancels and replaces previous version

CONVOI DE CALCUL LM71
CALCULATION CONVOY LM71

ATENTIUNE !
-Prezentul plan contine planul de cofraj pentru aripa A1EN stanga;
-Pentru perechea ei din dreapta se vor pastra aceleasi dimensiuni;
-A se vedea in schita din fig 1.

- NOTA:
- Aripa prefabricata se va confectiona din beton clasa C35/45 si otel PC60;
 - Dupa decofrare, fetele interioare ale peretilor si fata superioara a placii de baza se vopsesc cu suspensie de bitum filerizat in dublu strat;
 - Pentru manevrarea prefabricatului se vor lasa orificii amplasate conform planului. Dupa montarea definitiva in amplasament a transoarelor, se vor umple cu mortar;
 - Aripile prefabricate se vor amplasa pe blocurile de fundatie monolitice prin intermediul unui strat de mortar de ciment care va fi dicatut din:
-un strat de nivelare de 2cm
-un strat de 1 cm de fixare pe blocul monolit
Inaintea aplicarii mortarului, suprafaa blocului se va curata bine de toate impuritatile;
 - La executie se vor respecta cu strictete prevederile din prescriptia tehnica NE 013-2002 "Cod de practica pentru executarea elementelor prefabricate din beton, beton armat si beton precomprimat" si din Caietul de Sarcini.
 - Compactarea pamantului de umplutura din interiorul aripii se va face cu placa vibratoare.

ATENTION !
-This drawing represents the formwork plan for the left A1EN wing.
-For the right A1EN wing, there will be maintained the same dimensions but the formwork will be placed in mirror;
-To be seen the figure no. 1.

- NOTE:
- The prefabricated wing will be executed of concrete class C35/45 and PC 60 steel;
 - After removing the formwork, the interior sides of the walls and the upper side of the bottom plate are painted with filler bitumen suspension in double layers;
 - To operate the prefabricated element will be provided holes located acc. to plan. After the definitive mounting of the section in location, the holes will be filled with mortar.
 - The prefabricated wings will be placed on the monolith foundation blocks by a cement mortar layer composed by:
-a levelling layer of 2 cm. thickness
-a layer of 1 cm. to fix on the monolith block.
Before mortar laying, the foundation block surface will be well cleaned by all the impurities.
 - During work construction there will be strictly applied the provisions of the technical prescription NE 013-2002 "Practice code for the concrete precast elements, reinforced and prestressed concrete" and Technical Specifications of this project.
 - Compaction of filling earth from inside the wings is done with vibrating plate.

Verificator / Expert Checker / Expert	Cerinta Requirement	Semnatura Signature	Referat / Expertiza Report / Expertise		
PROIECTANT / DESIGNER:		Sef de echipa Team leader		Data Date	
Aprobat Approved		C. Teodorescu		01.2013	
Verificat Checked		R. Tudorascu		01.2013	
Subcontractant / Subcontractor				Semnatura Signature	
Aprobat Approved		A.M. Baicu		01.2013	
Proiectat Designed		F. Ioanidi		01.2013	
"Reabilitarea liniei c.f. Frontieră - Curtici - Simeria, parte componentă a coridorului IV Pan - European pentru circulația trenurilor cu viteză maximă de 160 km/h"		Tronsoanul 2 : km 614 - Gurasada		Project 9i 35311.1	
"Rehabilitation of the Railway Line Border - Curtici - Simeria, component Part of the IV Pan - European Corridor for the Trains Circulation with maximum speed of 160 km/h"		Section 2 : km 614 - Gurasada		Faza / Phase: PTH+CS / TD+TS	
Denumire desen / Drawing name: PLAN COFRAJ ARIPIA TIP A1EN SHUTTERING PLAN WING A1EN TYPE					
Scara / Scale 1:20	Revizia / Revision 1/05.2013	Cod desen / Drawing Code PT.02.02.00.PO.013		Nr / No 13	